

A Masterpiece of the Sword Smiths Art

BY PETER JOHANSSON

The sword N4516 is an unusually fine example of the sword smiths craft. It is masterfully made and an ingenious work of design in the Gothic tradition.

FUNCTION AND HEFT

A versatile long sword like the N4516 was effective in cuts against unarmoured targets and excelled in thrusting. Its sturdy blade is well suited for half-sword techniques and the massive pommel may be used as a club. The angle of sharpening is some 30 degrees, making for an edge that is both acute and resilient.

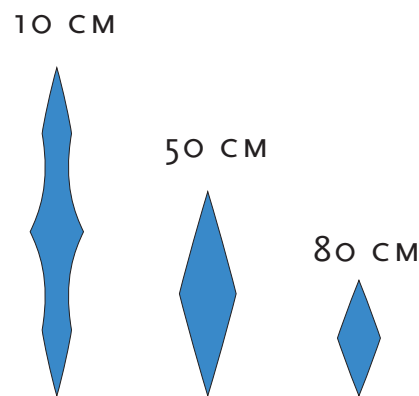

Even with a rather hefty weight of 1650 grams, the N4516 is an supremely agile and responsive weapon as a result of a well adjusted distribution of mass.

Important factors in the function of swords are *Pivot Points*, *Vibration Nodes* and *Point of Balance*. The illustration shows where these are situated in the N4516.

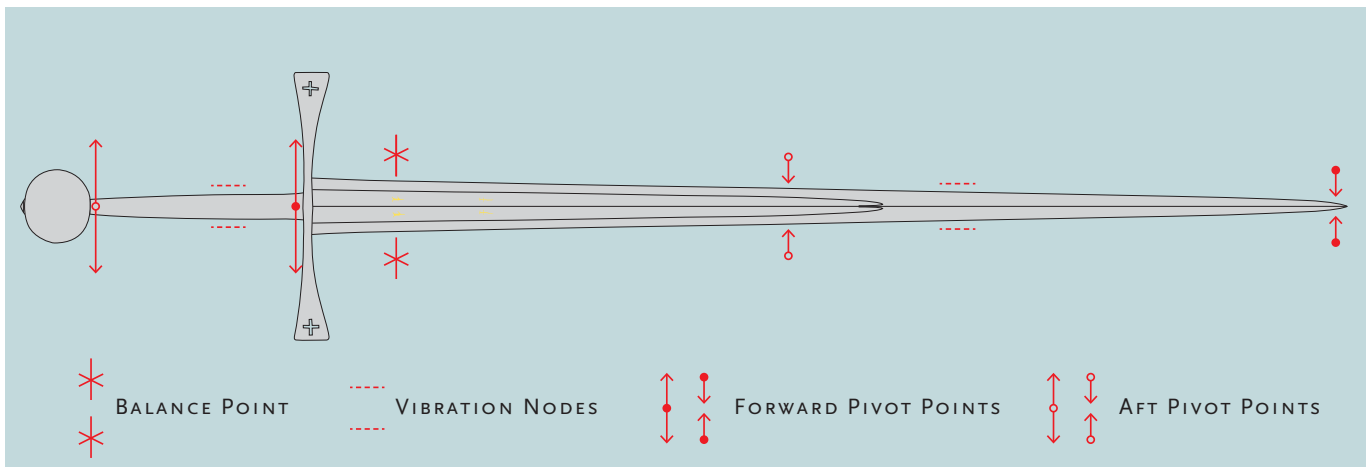

The *Point of Balance* is where swords balance while stationary. However, swords are designed for motion. How well balanced a sword is can be judged by the placing of the *Forward* and *Aft Pivot Points*. The forward pivot points helps aiming the blade at the opponent in wards and guards, while the aft pivot point allows the sword to be quickly brought around in preparation for a blow.

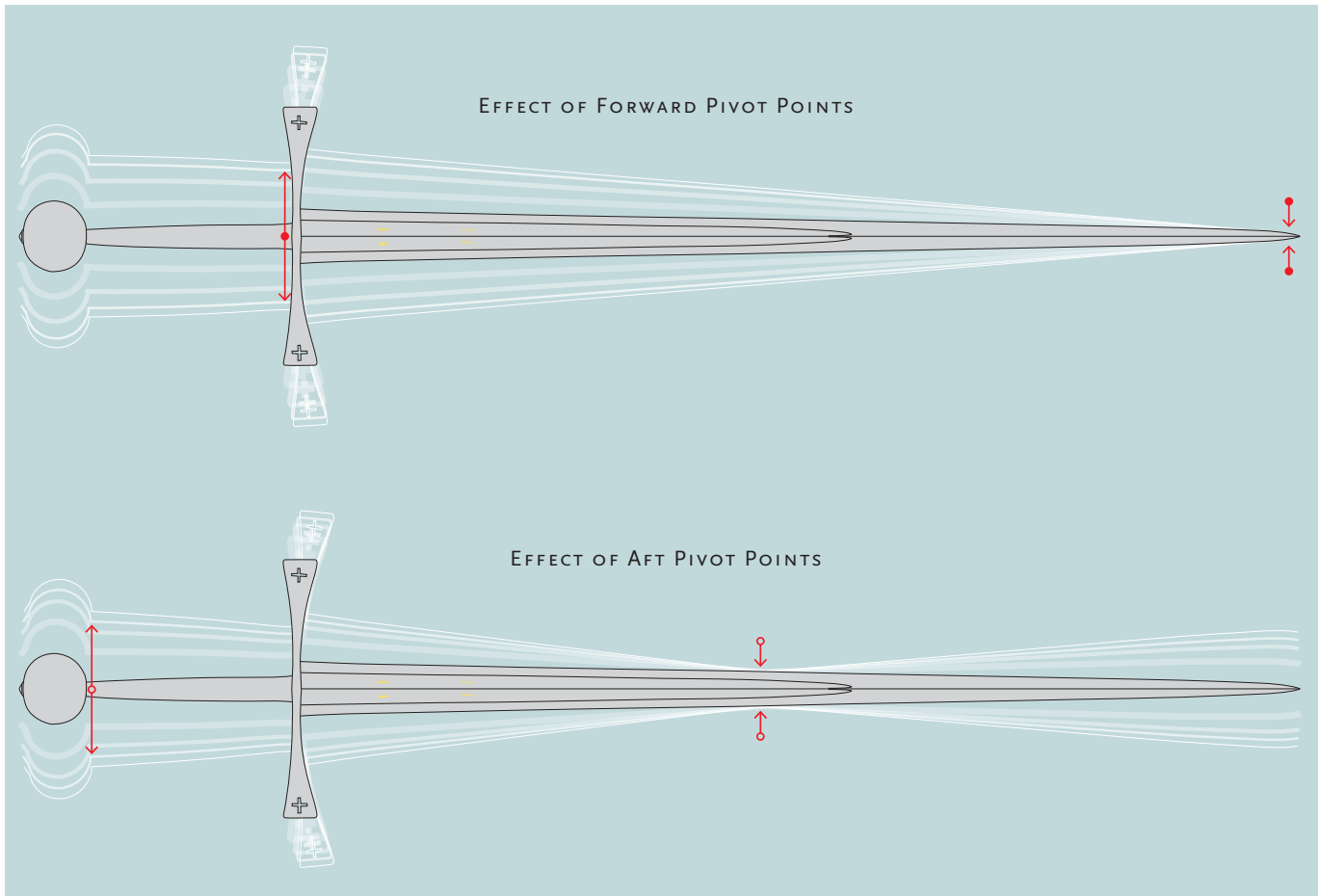

The *Nodes of Vibration*, are places where vibrations are cancelled out. This will have an effect on how the sword behaves in contact with other weapons and on impact with targets.

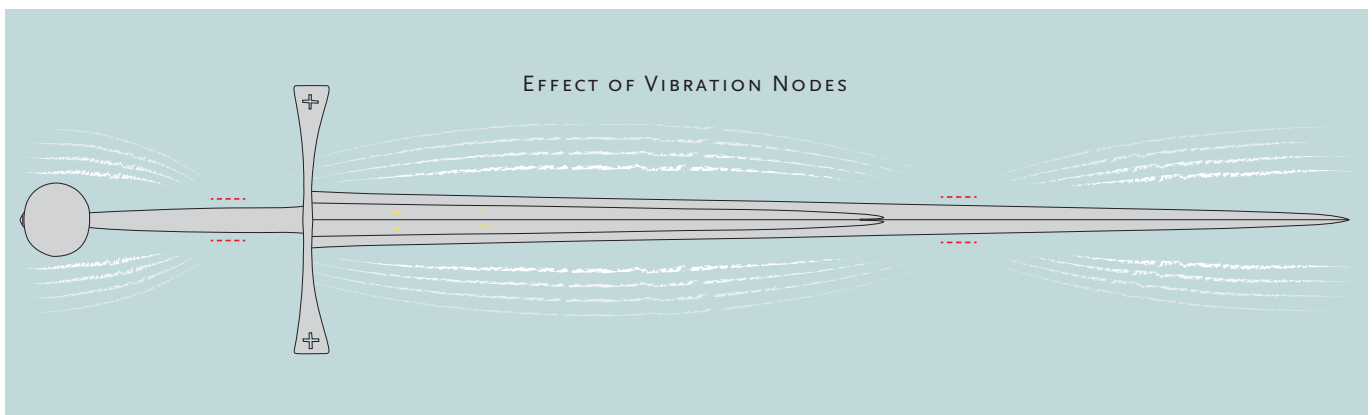

GOTHIC AESTHETICS IN THE DESIGN OF SWORDS

The coherence of elements of design and unity of proportions was very important to medieval aesthetics.

Analysis of the proportions of medieval swords according to design techniques known from surviving architectural drawings from the period indicate that geometric drawing was also known and used by cutlers or sword smiths.

The use of geometry in design has several benefits. It is a practical way to establish specifications for work that is divided between several expert craftsmen, as was the case in the production of swords. Geometric structures are also simple to scale to any size and easy to memorize.

Geometry and number were to the medieval mind charged with symbolic meaning and this may be important for a weapon that was an emblem for worldly power and prowess but also a symbol of the spiritual fight against evil. Letters and symbols inlaid in blades served as religious invocations and magical talismans. Likewise, the use of geometry in the design of the sword transformed it into a divine instrument, possessed of a perfect wholeness derived from the unity and harmony of its parts.

The illustrations below show how geometry may have been used in the design of N4516. The defining elements of the structure; the vesica, the octagon, the rotated and inscribed squares and the interaction between square and circle are all commonly used by medieval architects in the design structure for abbeys and cathedrals.

Blue lines are devices for construction. White lines mark the basic geometry while red lines define the proportions of the sword.

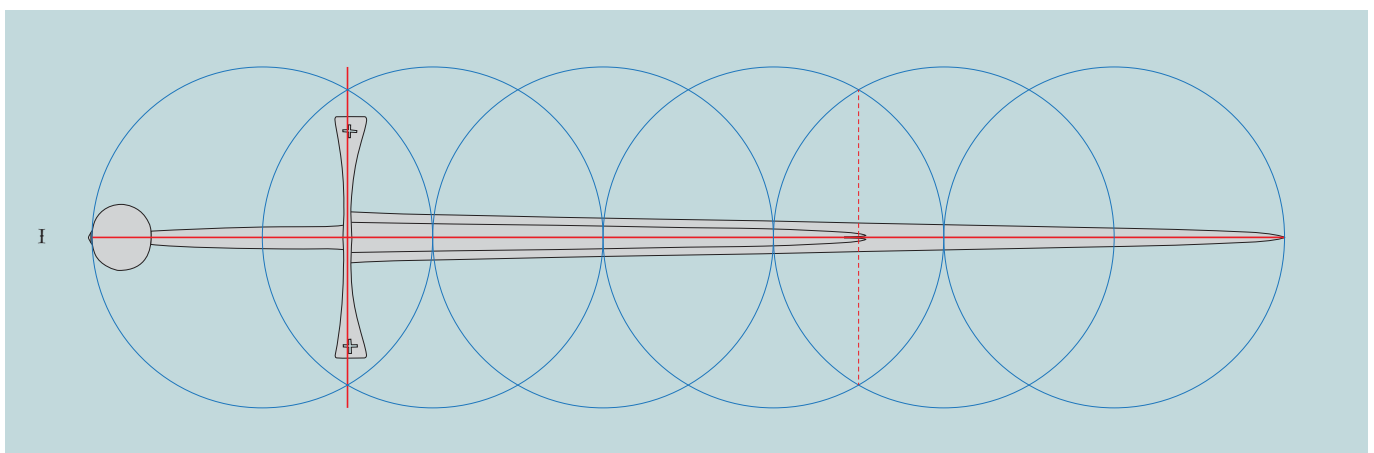

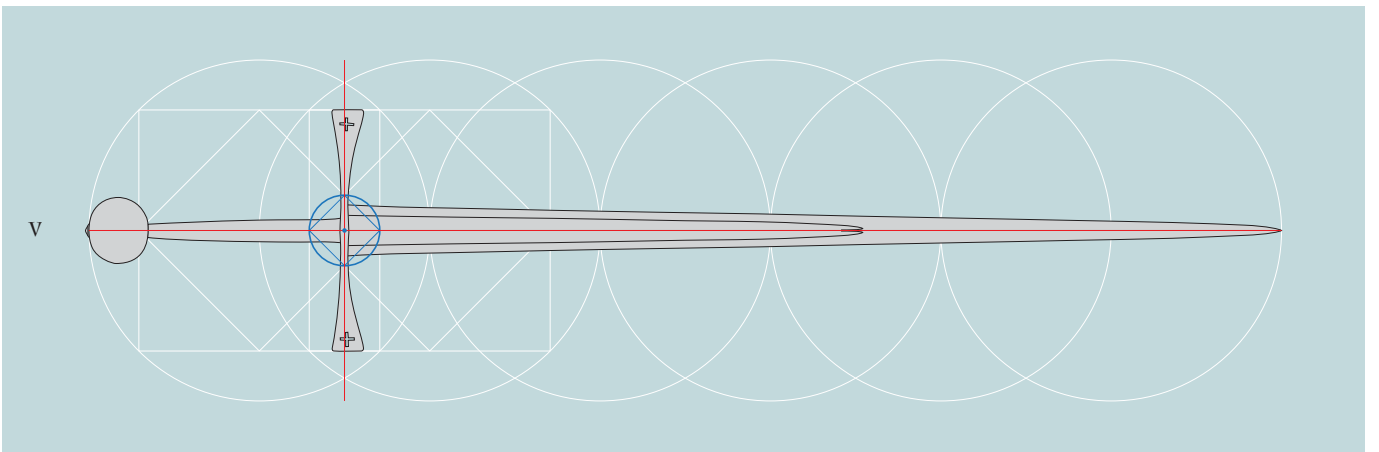
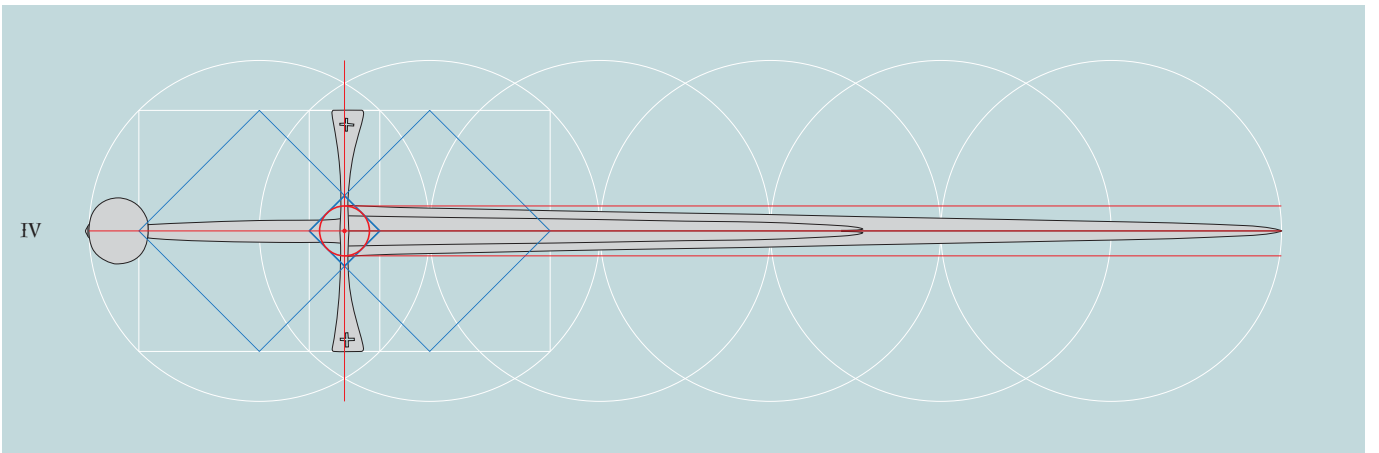
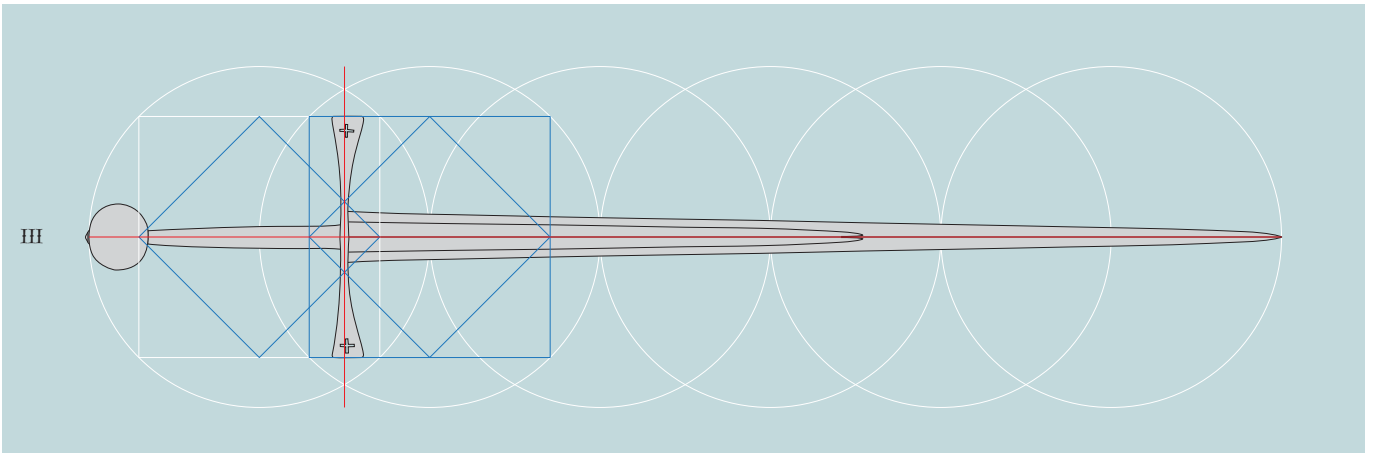
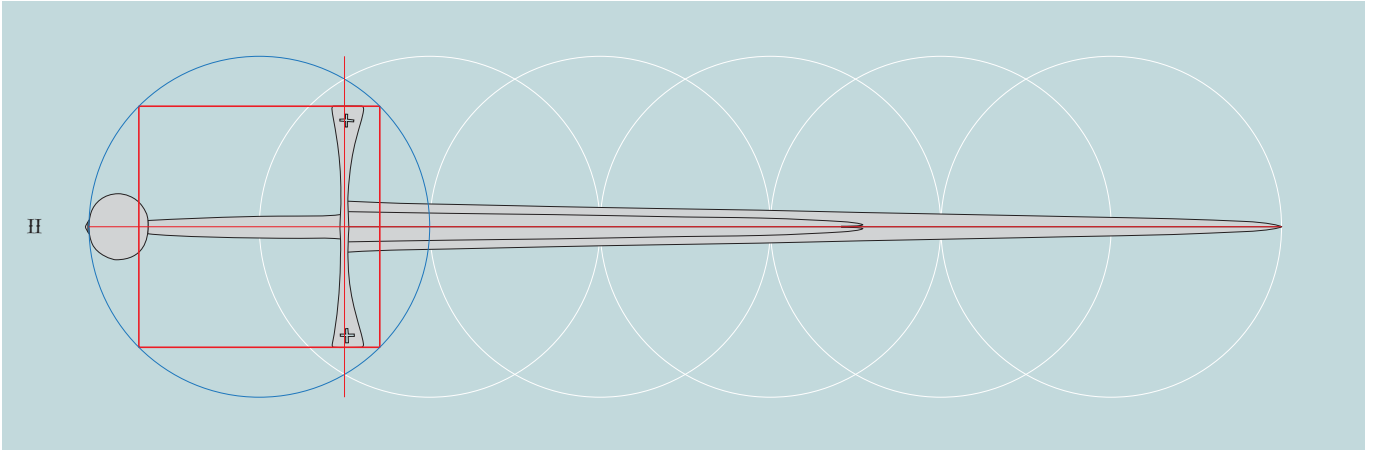

VI

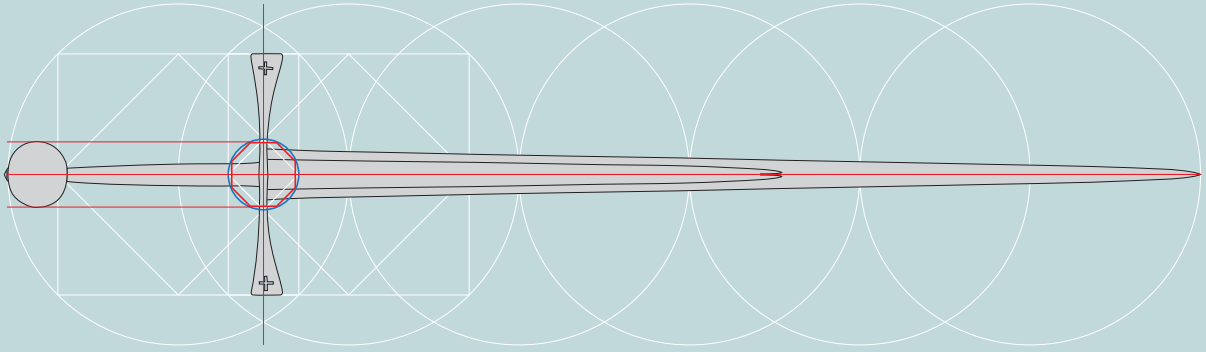

VII

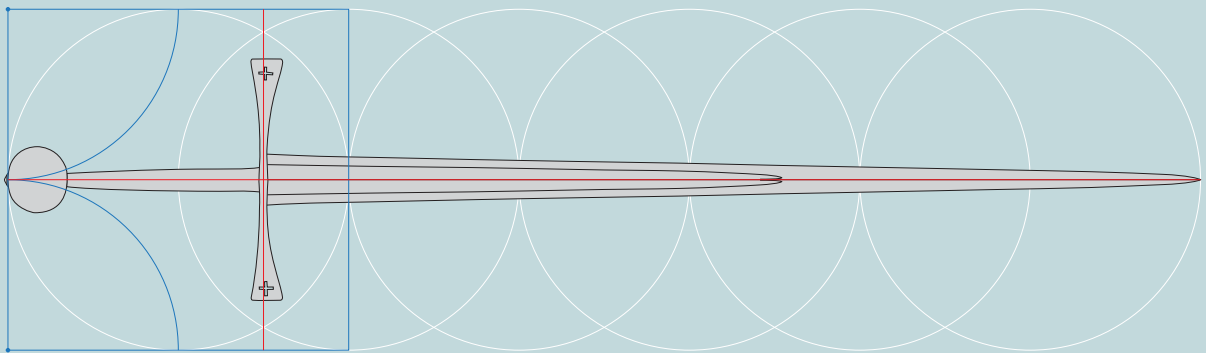

VIII

